



The People You Know. The Products You Trust.



A7 TornadoTM

8.4 Cubic Yard Regenerative Air Street Sweeper

*Sweeper shown with optional equipment



- PM 10 Certified
- WhisperWheel Fan Technology
- Schwarze Sweeps-in-Reverse
- DC Auxiliary Hydraulic Pump



Quality	Performance	Public Safety	Value	Customer Support

800.879.7933

www.schwarze.com

↑ 40" Dump Height

A7 Tornado™

8.4 Cubic Yard Regenerative Air Street Sweeper



◀◀ Sweeps-In-Reverse

*Optional Equipment Shown

Increased hopper screen surface area through saw-tooth design.

Easy to use backlit switches with text and icon labels.



Shielded broom motor reduces entanglement of strings & twine.



Also available on short wheel base M2 chassis.

MUST HAVE OPTIONS

INCREASED WATER

Extra 350 gallon polyethylene water tank

INCREASED SIDE BROOM USABILITY

Add The Gutter Broom Extension Override (Schwarze GEOSM)

GREATER DURABILITY

Choose the Stainless Steel Hopper option

AT YOUR FINGERTIPS

In-cab down pressure control

CLEANING IN TIGHT AREAS

8" auxiliary hand hose

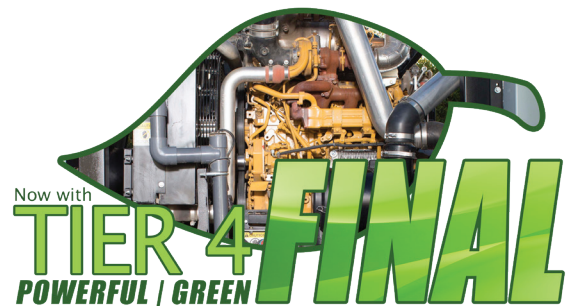

VALUE

We are dedicated to satisfying our customers by providing the most advanced training for their specific needs. Our training programs are designed to help operators of all skill levels learn the best operating practices for their Schwarze equipment.



PERFORMANCE

There is a lot riding on creating solutions that are suited to the particular needs of different industry applications. Innovation often involves high technology, but doesn't always have to be. Some of our best ideas have been simple, based on a clear and deep understanding of our customers' working lives.



QUALITY

In a Schwarze product, end user concerns like fuel efficiency, serviceability, durability, purchase cost, service cost, etc. are all taken into account. We also consider the needs and strive for ease of use and application optimization. It should be obvious, because when it comes to cost of ownership, quality pays.



PUBLIC SAFETY

No other name speaks safety louder than Schwarze. Protecting operators, those around them, and minimizing our environmental impact are traditional values that continue to shape our product design philosophy.



CUSTOMER SUPPORT

Being a Schwarze customer means having a complete set of services at your fingertips. Schwarze can offer you a long-term relationship, protect your revenue and provide a full range of customer solutions, delivered by passionate people. At Schwarze, we don't see effective service and support just as an added value to your purchase, but as an integral part of it.



Also Available from Schwarze Industries, Inc:



A7 Tornado

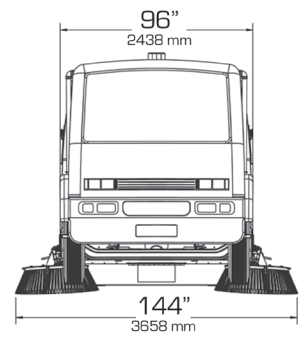
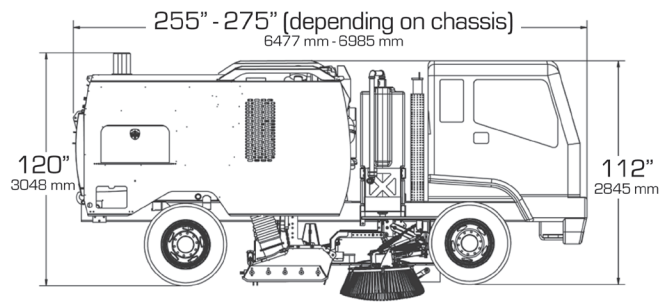

*TYPICAL MEASUREMENTS SHOWN, EXACT DIMENSIONS DEPENDING ON OPTIONS AND TRUCK MANUFACTURER

SWEEPING PATH

Pickup head only	90 in (2286 mm)
Head and 1 broom	117 in (2972 mm)
Head and 2 brooms	144 in (3658 mm)

CHASSIS

Mounts on various chassis to meet requirements

SWEEPER BODY

Construction	Welded 10-gauge stainless steel plate
Safety props	Lift spacers

STANDARD ENGINE

Model/type	4045T in-line 4 cylinder
Aspiration	Tier 4 Final turbo-charged diesel
Manufacturer	John Deere
Displacement	275 cu in. (4.5 L)
Brake horsepower	134 hp (100 kw)
	@ 2400 rpm
Torque	398 ft lb (540 Nm)
	@1600 rpm
Air cleaner	Centrifugal precleaner; dry type with safety element and restriction indicator
Oil filter	Full-flow/spin-on
Stroke	5 in (127 mm)
Bore	4.20 in (106 mm)
Compression ratio	19 to 1
Safety shutdown	Three-point automatic
Throttle control	Electronic

SWEEPER ELECTRICAL SYSTEM

Voltage	12 V
Engine alternator	90 amp

DUST CONTROL SYSTEM

Type	High pressure/low volume
Capacity	250 gallon (946 L)
Tank construction	Polyethylene filter; 50 mesh; cleanable
Fill diameter	2.5 in (63.5 mm)
Fill hose	25 ft (7620 mm)
Controls	Electric; in-cab
Nozzles	2 on each broom; 5 around suction head; 2 inside suction nozzle; 2 on front axle; 2 inside hopper
Water level gauge	In-cab

INSTRUMENTATION

Auxiliary engine	Flat panel display; tachometer; hourmeter; voltmeter; temperature gauge; oil pressure gauge; warning icons
------------------	--

FAN SYSTEM

Type	Closed-face radial
Drive	Direct via 5 groove; banded power belt
Construction	Hardox steel
Balance	1.5 grams on 2 sides
Diameter	32.75 in (832 mm)
Housing lining	Bolt-in corded rubber
Mounting	2 regreasable sealed bearings
Vacuum enhancer	For heavy/light material; in-cab indicator

PICKUP HEAD

Type	Dual chambered full-width blast orifice
Operating direction	Forward and reverse
Suspension	Adjustable spring balanced
Length	90 in (2286 mm)
Pressure hose diam	14 in (355.6 mm)
Suction hose diam	14 in (355.6 mm)
Hose construction	3/8 in (9.5 mm) wire-reinforced molded rubber
Head area	3240 sq in (20903 sq cm)
Controls	Hydraulic raise and lower
Skids	Double wide tungsten carbide
Construction	Abrasion-resistant steel inlet and outlet transitions.

SIDE BROOMS

Type	Vertical steel digger
Location	Right; left; forward of pickup head
Diameter	44 in (1118 mm)
Drive	Hydraulic
Suspension	Torque-sensing spring
Wear adjustment	Automatic
Pressure	Manual
Speed	Variable; non-reversing
Segments	5 each side; disposable
Tilt angle adjustment	In-cab controls

DEBRIS HOPPER

Volumetric capacity	8.4 cu yd (6.4 cu m)
Usable Capacity	7.0 cu yd (5.4 cu m)
Dump angle	51 degrees
Floor angle	3 degrees
Lifting	Twin hydraulic cylinders
Hopper dump door	Hydraulic open, close, lock
Inspection doors	1 on each side, pressure vessel lock
Hopper dump height	40 in (1016 mm)
Debris screens	Sawtooth drop down

HYDRAULIC SYSTEM

Type	Dual output 2 section
Pump capacity	8 gpm @ 1800 rpm (30 lpm) per section for 16 gpm total
Drive	Direct gear
Maximum pressure	2750 psi (190 bar)
Reservoir	25 gal (94 L)
Filter	10 micron; spin on
Protection	Pressure relief valve
Controls	Electro-hydraulic

AUXILIARY HYDRAULIC SYSTEM

Type	Gear type; driven by electric motor
Function	Lower hopper; open/close hopper door; raise brooms and pickup head

PAINT

One coat of sealer/primer and two coats of Dupont imron elite polyurethane in standard white color

Note: Design and specifications subject to change without notice.

*Ask us about our optional:



Affiliates:



© 2019 Schwarze Industries
1055 Jordan Road
Huntsville, AL 35811
800.879.7933
An Alamo-Group Company

