

THE BIGGEST & THE BEST

PACKED WITH 100 DGE OF CLEAN ENERGY,
YOUR FAVORITE LABRIE SIDE LOADER
IS READY TO HIT THE ROAD,
AND GET HOME LATE...

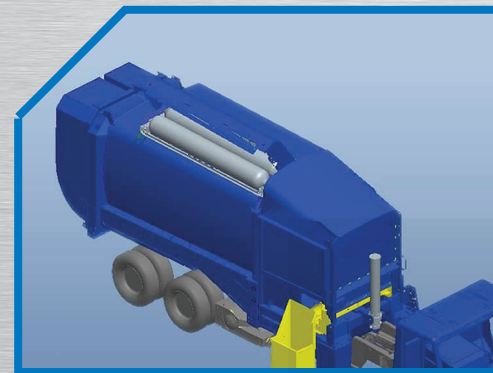

- Low impact on weight distribution
- Fully integrated roof-mount design with hinged covers for easy inspections

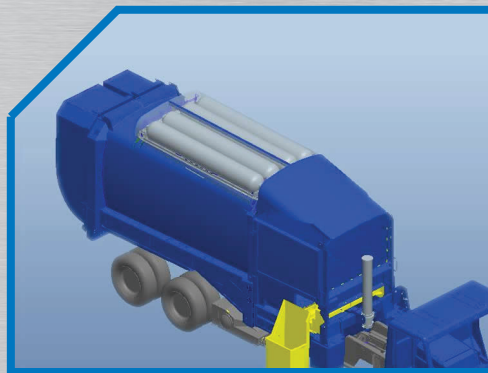
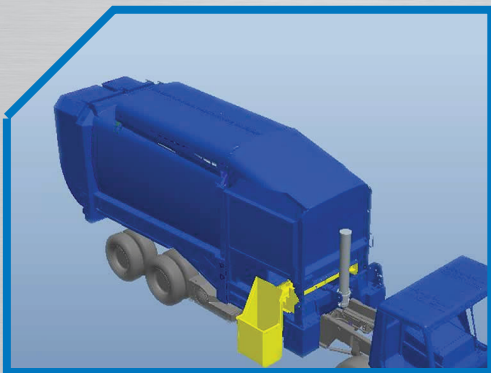

LABRIE CNG: DELIVERING A CLEANER WAY OF DOING BUSINESS SINCE 2001



CNG READY
SINCE 2001

CNG SYSTEM CONFIGURATION

Total Diesel Gallon Equivalent (DGE) capacity BODY STYLE	Body Size (yd ³)	Behind the Cab Configuration			Roof Configuration				Frame Configuration		Tailgate Configuration	
		50 DGE	66 DGE	82 DGE	60 DGE	66 DGE	75 DGE	100 DGE	63 DGE	22 DGE ^A	86 DGE	96 DGE
Labrie Automizer Side Loader	20-37	•	•	•	•		•	27c.y. Min.		•	•	•
Labrie Alleygator Side Loader	20-30	•	•	•	27c.y. Min.	•	27c.y. Min.				•	•
Labrie Expert Side Loader	15-37	•	•	•	•		•	27c.y. Min.			•	•
Labrie Minimax	10-14					•						
Labrie Sprinter	24-35	•	•	•	27c.y. Min.		27c.y. Min.					
Labrie Top Select	30-48	•	•	•								
Leach 2R-III, Alpha-III & Split Rear Loaders	14-32	•	•	•	• ^D	20c.y. Min.	• ^D	25c.y. Min.	25c.y. Min.			
Mini Rear Loader	8-17	•	•	•		10,5 & 17 only						
Wittke Starlight, Superduty, Featherweight Front Loaders	30-44				•		•			•	•	•
TANKS												
Number of tanks		3	4	5	4	4	5	4	2	1	2	3
Diesel Gallon Equivalent (DGE) capacity per tank (gallons)		16.5	16.5	16.5	14.8	16.5	14.8	25.8	41-22	22	43	43-10
SYSTEM IMPACT ON BODY DESIGN												
Estimated increase to overall height (OAH) (inches)		N/A	N/A	N/A	10in ^B	18	10in ^B	13in ^C	N/A	N/A	N/A	N/A
Estimated increase to wheelbase (WB) (inches)		18-24in	18-24in	18-24in	N/A	N/A	N/A	N/A	N/A	N/A	N/A	N/A

A) 22 DGE frame configuration in addition to a roof mounted configuration
B) Estimated increase to overall height (OAH) 17 1/2" for Leach body
C) Estimated increase to overall height (OAH) 20 1/2" for Leach body
D) On Leach Alpha-III, on body sizes 25 yd³ and up



LABRIE ENVIROQUIP GROUP

Labrie Enviroquip Group is one of the largest manufacturer's of refuse and recycling collection vehicles in North America. Our product lines of Labrie, Leach, and Wittke are renowned to be the most reliable, efficient, productive, and innovative in the solid waste industry today.

Throughout our history, we have been recognized for the design and production of the highest quality vehicles available on the market, while our customers benefit from a single trusted source of engineering expertise.

At Labrie we continually push the boundaries of innovation to provide a greener, safer, smarter and more efficient way of waste management and collection.

We are committed to building and delivering the finest refuse collection equipment in the industry to suit all of your collection needs. With the strongest dealer network in the industry (over 45 distribution points across the continent), our stock and demo program, engineering expertise, and the Labriepius 24/7 customer support center, Labrie delivers the ultimate ownership experience.

Labriepius is Labrie's full service customer support center located in the U.S. Its mission is to provide quality replacement parts and premium hands-on field support to Labrie equipment owners. Labriepius is the single source for Labrie, Leach, Wittke and Pendpac OEM and selected all makes of parts.

DRIVE EXCELLENCE

Labrie is certified ISO 9001:2015 and attests to the quality of these products. Labrie has made every reasonable effort to ensure that the information contained in this brochure is accurate. However, we accept no responsibility for any errors or omissions, and we reserve the right to modify designs, characteristics and products at any time. Contact Labrie for prices and options or to obtain the phone number of your local Labrie distributor. For the most recent version of our spec sheets, please go to Labrie website at www.labriegrup.com. In case of discrepancy, the Web version takes precedence over any printed literature. © Labrie Enviroquip Group 2019 - Printed in USA



Labrie (Head Office)
175-B, route Marie-Victorin, Levis, Quebec, Canada, G7A 2T3
Toll free: 800 463-6638 • Phone: 418 831-8250 • Fax: 418 831-5255
info@labriegrup.com • www.labriegrup.com



Labriepius (USA Office)
1981 W. Snell Road, P.O. Box 2785, Oshkosh, Wisconsin, USA, 54903-2785
Toll free: 800 231-2771 • Phone: 920 233-2770 • Fax: 920 232-2496



EnviroQuip Parts, LLC
1198 Shattuck Industrial Boulevard, LaFayette, GA, 30728
Phone: 1-706-628-2467 • Fax: 1-706-639-9275
www.partseq.com