



TOP SELECT™

 **labrie**

CNG
CNG READY
SINCE 2001

VERSATILE CURBSIDE RECYCLING. PIONEERED BY LABRIE.



Top Select™ 1000



Top Select™ 2000 Maximizer



CURBSIDE RECYCLING. PIONEERED BY LABRIE.

The Top Select™ is a recycling unit built for manual and semi-automated collection of residential recyclable material.

The Top Select™ optimizes collection operations by offering 2 to 7 compartments for pick up of different streams at curbside, for precise on-site sorting.

Optional cart attachments are available for easy roll carts pick-up.

EASY, SAFE 1-MAN OPERATION. MAXIMUM EFFICIENCY.

The Top Select™ can be operated from several driving configurations, for optimal one-man operation.

Stand-up drive positions are available on either or both sides of the truck.

SMOOTH OPERATION. MAXIMUM PRODUCTIVITY.

Two hydraulic cylinders with fully adjustable cushions on both ends allow a smooth and easy operation of the loading bucket. This combination of features generates high levels of collection performance: 500+ households per route, and up to 10,000 lbs payloads with the Maximizer option.



VISUAL CHECK. ON ROUTE ADJUSTABILITY

Steel mesh along the top of the body offers a visual check on material levels for easy on the route adjustability and monitor the position of the Maximizer panel.

Both interior panels and loading bucket separators are adjustable at 6" (152 mm) intervals.

HYDRAULIC MAXIMIZER

Impressive 84" stroke-travel hydraulic Maximizer. Adjustable "on-the-route" compartment; offering maximum compaction.





SEPARATORS & MULTI-FEATURE BODY CONTROLS

Lightweight recycled plastic separators can be moved quickly & easily by hand. No tools needed.

Easy access to the multi-feature body controls from either the left or the right side of the vehicle, on all Labrie cab conversions.

COMPARTMENTS

The Top Select can accommodate up to seven adjustable compartments and are designed with a unique over-the-top dumping system.



PREMIUM PRODUCTS COME WITH PREMIUM SUPPORT.

Labrie is committed to delivering the ultimate ownership experience throughout North America. Our pursuit of excellence continues long after a Leach™, Labrie™ or Wittke™ is put into service.

OUR NORTH AMERICAN NETWORK IS QUALITY DRIVEN:

- **Labrieplus 24/7 customer support system**, provides quality replacement parts, premium hands-on field and live assistance. Peace of mind guaranteed.
- **A network of over 45 premium distributors** located throughout the United States and Canada are highly trained to assist you; providing live assistance from a dedicated staff of professional representatives to support all of our Leach™, Labrie™ and Wittke™ products.

labrie
Ontario, California

labrie
San Luis, Sonora, Mexico

labrieplus
SERVICE PARTS
Oshkosh, Wisconsin

labrieplus
SERVICE PARTS
LaFayette, Georgia

labrieplus

labrie
Quebec, Canada

- Premium Distributor Locations
- Regional Sales Managers
- Field Service Representatives
- Technical Advisors / Demo Operators

Visit www.labriegrup.com
to view a complete listing of our premium distributor network



Body Dimensions	34yd ³ (31+3)	42yd ³ (38+4)	45yd ³ (44+1)	48yd ³ (44+4)
A. Overall Length, Tailgate Closed (in.)	281	288	298	324
Overall Width (in.)	102	102	102	102
B. Overall Height Above Frame, Tailgate Closed (in.)	90	102	102	102
C. Overall Length, Tailgate Open (in.)	305	312	352	348
D. Overall Height Above Frame, Tailgate Open (in.)	137	163	158	163
E. Overall Length, Dumping Position (in.)	374	397	433	433
F. Overall Height Above Frame, Dumping Position (in.)	201	209	235	235
G. Overall Height Above Frame When Dumping (in.)	124	152	152	152
H. Distance between bottom of bucket and chassis frame rail (in.)	27	27	27	27

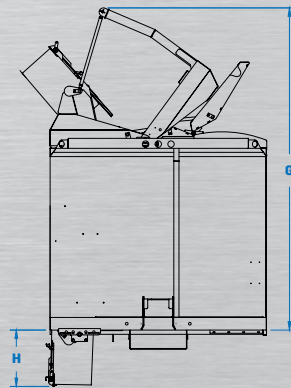
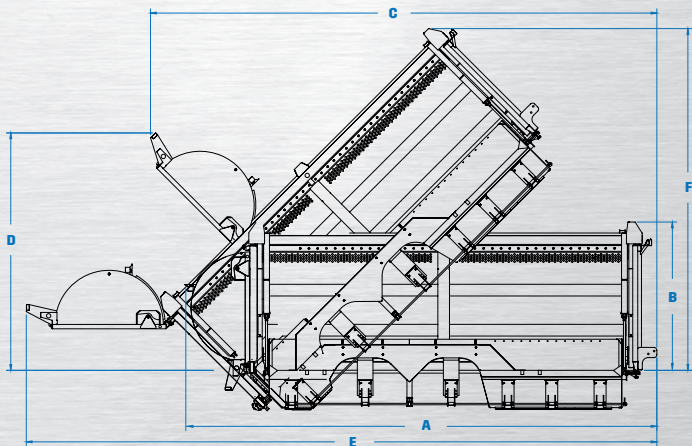

Body Specifications

Body Floor	3/16" 50W 50,000 psi
Body Sides	12ga A1011 CS
Body Roof (fixed)	16ga A1011 CS
Body Roof (mobile)	14ga A1011 CS
Tailgate	12ga A1011 CS

Loading Bucket Specifications

Lifting Capacity	1,000 lbs
Loading bucket width	18"
Loading height above frame	0"

Hydraulic Specifications

Pump	Gear
Pump Capacity	20 gpm @ 1200 rpm
Max. Operating Pressure	2,000 psi
Oil Reservoir	40 gal

Performance Specifications

Bucket complete cycle time	15 - 17 sec @ 700 rpm
Maximizer complete cycle	28 - 35 sec @ 700 rpm
Tailgate Open	18 sec @ 700 rpm
Tailgate Close (with Safety Flow limiter)	20 sec @ 700 rpm
Body Up (depending on body size)	35-45 sec @ 1500 rpm
Body Down (depending on body size)	25-35 sec @ 700 rpm

Maximizer (for compartment optimization¹)

Packing Force on Recyclables (towards front)	40,000 lbs
Packing Force on Paper (towards tailgate)	18,000 lbs

¹Not intended for compaction

Cylinder Specifications

Body Lifting Cylinder (short deck)	4 stages 6-1/16" bore x 150" stroke
Body Lifting Cylinder (long deck)	4 stages 6-1/16" bore x 180" stroke
Loading Bucket Cylinders	3-1/4" bore x 1-1/2" rod x 15-1/2" stroke
Maximizer Cylinder	5" bore x 3" rod x 84" stroke
Tailgate Cylinders	2-1/2" bore x 1-1/2" rod x 28" stroke

Note: Specifications subject to change without notice



THE LABRIE GROUP

The Labrie Group is one of the largest manufacturer's of refuse and recycling collection vehicles in North America. Our product lines of Labrie™, Leach™, and Wittke™ are renowned to be the most reliable, efficient, productive, and innovative in the solid waste industry today.

Throughout our history, we have been recognized for the design and production of the highest quality vehicles available on the market, while our customers benefit from a single trusted source of engineering expertise.

At Labrie we continually push the boundaries of innovation to provide a greener, safer, smarter and more efficient way of waste management and collection.

We are committed to building and delivering the finest refuse collection equipment in the industry to suit all of your collection needs. With the strongest dealer network in the industry (over 45 distribution points across the continent), our stock and demo program, engineering expertise, and the Labriplus 24/7 customer support center,

Labrie delivers the ultimate ownership experience. Labriplus is Labrie's full service customer support center located in the U.S. Its mission is to provide quality replacement parts and premium hands-on field support to Labrie equipment owners. Labriplus is the single source for Labrie™, Leach™, Wittke™ and Pendpac™ OEM and selected all makes of parts.

DRIVE EXCELLENCE



Labrie is certified ISO 9001-2008 and attests to the quality of these products. Labrie has made every reasonable effort to ensure that the information contained in this brochure is accurate. However, we accept no responsibility for any errors or omissions, and we reserve the right to modify designs, characteristics and products at any time. Contact Labrie for prices and options or to obtain the phone number of your local Labrie distributor. For the most recent version of our spec sheets, please go to Labrie website at www.labriegrup.com. In case of discrepancy, the Web version takes precedence over any printed literature. © Labrie Enviroquip Group 2020. - Printed in USA



Corporate Office

175-B, route Marie-Victorin,
Levis, Quebec, Canada, G7A 2T3
Toll Free: 800 463-6638 • Phone: 418 831-8250
Fax: 418 831-5255
info@labriegrup.com • www.labriegrup.com



Parts & Service Canada

175-A, route Marie-Victorin
Lévis, Québec, Canada, G7A 2T3
Toll Free: 1-800-463-6638
<https://labrieparts.labriegrup.com>



Parts & Service USA

1198 Shattuck Industrial Boulevard
LaFayette, GA 30728
Phone: 1-706-628-2467
www.labriplusparts.com