



# Expert Series





# Expert Series

*DROP FRAME FLEXIBILITY, BECAUSE EVERY ROUTE IS DIFFERENT*

Introducing the Expert Series, the most versatile waste collection vehicle on the market. Since 1984, we've been performing our own factory drop frame modifications, enabling us to offer customized solutions to meet our customers' unique needs.

The Expert is designed for efficient waste collection, whether it's manual, semi-automated, or fully automated. Hopper access from both curbside and street side makes it easy to collect waste in alleys and one-way streets. With various configurations and numerous options available, it's hard to find a situation where the Labrie™ Expert wouldn't be a perfect fit.

## Laying the foundations for a truly exceptional product.

### LABRIE™ INNOVATIONS

With a strong emphasis on innovation, Labrie's engineering team has crafted a comprehensive range of customizable options to cater to even the most stringent customer requirements. We are poised and eager to embrace emerging industry trends and fulfill evolving customer demands. This perpetual cycle of innovation positions Labrie™ as the forefront leader in side loader solutions across North America.

### WEIGHT DISTRIBUTION

Over years of innovation, Labrie™ trucks prioritize ideal weight distribution in all models. Our ongoing objective is to achieve the perfect material balance, ensuring models collect more waste while maintaining the highest legal payload.

The rounded, tapered shape of the body maximizes compaction by concentrating material at the back.

15 yd<sup>3</sup> to 37 yd<sup>3</sup> body sizes

AR Steel liners on the hopper floor and side walls

Proportional joystick, electric over hydraulic

Crusher panel

Tailgates ranging from 0 yd<sup>3</sup> to 6 yd<sup>3</sup> based on body capacity

Tailgate auto-latch closes straight down to protect rubber seal

Zinc-plated hydraulic tubing

**Helping Hand™**

- 10 foot reach
  - 400 lb lifting capacity
  - 13 sec packing cycle
- Dual Helping-Hand™ configuration available

Hopper enclosed arm dumps directly into packer area

Large sump



**ENVIROLINK™ HAS LAID THE FOUNDATIONS FOR A BRAND-NEW ERA IN TRUCK INTELLIGENCE.**

An improved multiplex network and analog system, cameras and monitors, scales, diagnostic tools, safety interlocks, alerts, GPS tracking, and more are now packaged in a more precise, reliable, and efficient Smart Collection Package.

	AUTOMATED	MANUAL	RESIDENTIAL	COMMERCIAL	DEMOLITION	ORGANICS	ALLEYS TIGHT AREAS	RECYCLING	TIPTO DUMP	FULL EJECT	SPLIT BODY	50>82 DGE	50>96 DGE	50>100 DGE	60>97 DGE	FRAME	ROOF	CAB	TAILGATE	EV
Expert Series	●	●	●				●	●	●					◆ CNG			◆ CNG	◆ CNG	◆ CNG	●





### **IN-HOUSE DROP FRAME MODIFICATION**

Labrie™ is the only manufacturer that conducts the drop frame modification process in-house. This gives us direct control over the process, ultimately benefiting our clients.



### **MANUAL, SEMI-AUTOMATED OR AUTOMATED COLLECTION**

The Expert drop frame configuration excels in manual or semi-automated waste/recycling collection, featuring a low loading height.



### **SPLIT BODY VERSATILITY**

50/50, 40/60, or 60/40-split configuration for maximizing payload and adapting route diversion rates.



### **SINGLE SHEET OF STEEL ON THE BODY SIDES**

Enhanced strength and a seamless canvas for graphics, providing greater structural integrity, eliminating the need for reinforcement posts, and reducing the potential for weld seam cracks & corrosion.

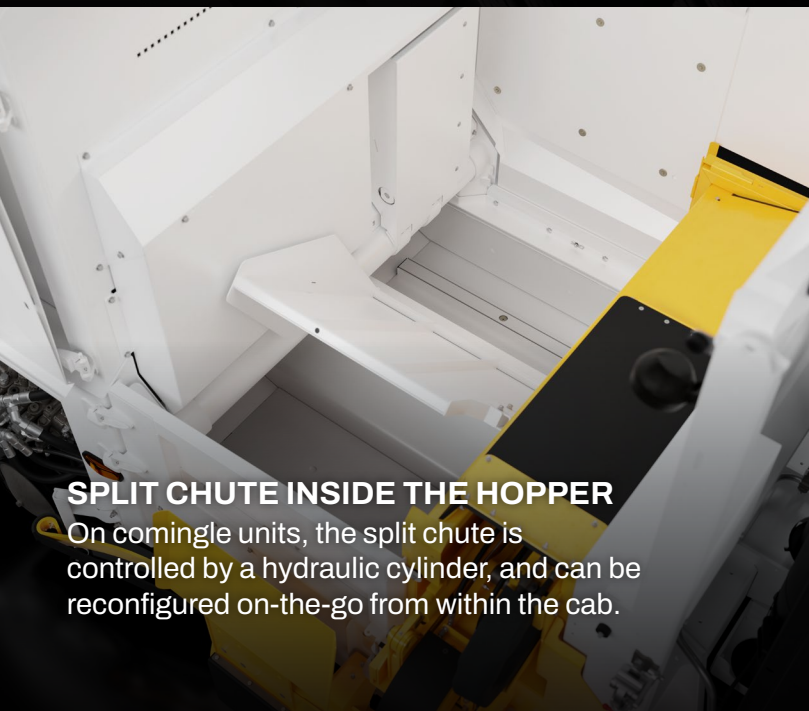

### **SPLIT CHUTE INSIDE THE HOPPER**

On comingle units, the split chute is controlled by a hydraulic cylinder, and can be reconfigured on-the-go from within the cab.



### **ENCLOSED HOPPER**

Ideal for preventing waste from flying onto the road and for keeping water, snow, and ice from accumulating overnight.

# Expert Series Specifications

## Body Specifications

Body Floor	3/16" 50W 50,000 psi
Body Sides (lower)	10ga A1011 80,000psi
Body Roof	12ga A1011 80,000psi
Tailgate	12ga A1011 80,000psi

## Arm Specifications (Automated Units)

Arm Lift Capacity	400 lbs
Arm Reach	84" (120" optional)
Swing out	16"
Arm Controls	Proportional joystick, electric over hydraulic

## Hydraulic Specifications

Pump	Single Vane (Manual) / Dual Vane (Automated)
Pump Capacity (Manual)	38 gpm@1200 rpm
Pump Capacity (Automated)	BODY: 20 gpm@700 rpm; ARM: 16 gpm@700 rpm
Max. Operating Pressure	3,000 psi (2,000 psi on single axle chassis)
Oil Reservoir (conventional cab)	65 gal

## Cylinder Specifications

Body Lifting Cylinder (15-20 yd <sup>3</sup> bodies)	4 stages 6-1/16" bore x 150" stroke
Body Lifting Cylinder (22 yd <sup>3</sup> bodies)	4 stages 6-1/16" bore x 165" stroke
Body Lifting Cylinder (27-31 yd <sup>3</sup> bodies)	4 stages 6-1/16" bore x 180" stroke
Packer Cylinders	4" bore x 2-1/2" rod x 40" stroke
Crusher Panel Cylinder	2" bore x 1-1/2" rod x 14-1/2" stroke
Tailgate Cylinders	2-1/2" bore x 1-3/4" rod x 39" stroke
Arm extension Cylinder (84" reach)	2" bore x 1-1/4" rod x 70" stroke
Arm extension 2nd Cylinder (120" reach)	2" bore x 1-1/4" rod x 36" stroke
Lifting Cylinder	3" bore x 1-1/2" rod x 16" stroke
Grabber Cylinder	1-1/2" bore x 1" rod x 6-1/4" stroke

## Hopper Specifications

Hopper Size (yd <sup>3</sup> )	4
Loading Height	5-1/2" above frame
Hopper Floor	3/16" 50W 50,000 psi
Hopper Floor wear plates	1/4" AR500 190,000psi
Hopper Sides (lower)	3/16" AR200 70,000 psi
Hopper Sides wear plates	0.157" AR450 175,000psi
Hopper Slope	1/4" AR500 190,000psi
Hopper Slope wear plates	1/4" AR500 190,000psi

## Packer Specifications

Compaction ratio (lbs/yd <sup>3</sup> )	850 (600 on single axle chassis)
Packer Panel Face Plate	1/4" 100QT 100,000 psi
Packer width	71"
Packer height	18"
Packer stroke	50"

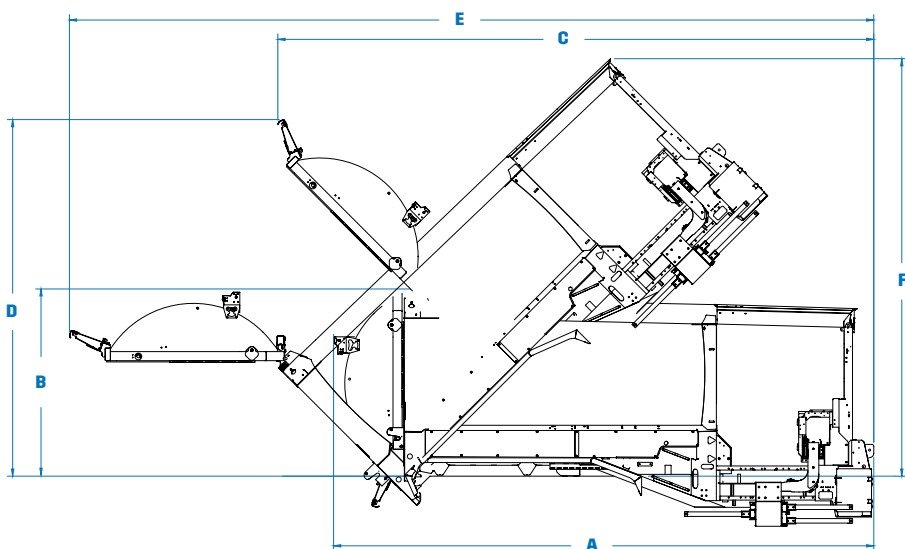
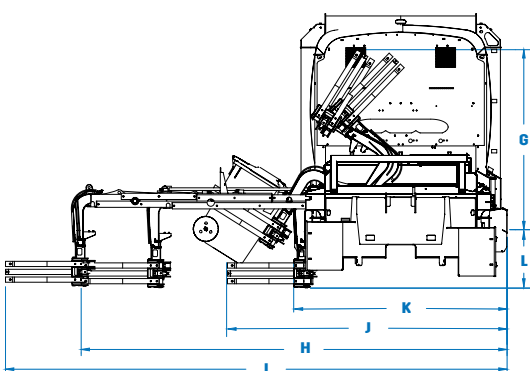

## Body Dimensions

	15YD <sup>3</sup> (15+0)	17YD <sup>3</sup> (15+2)	20YD <sup>3</sup> (20+0)	22YD <sup>3</sup> (20+2)	24YD <sup>3</sup> (20+4)	24YD <sup>3</sup> (22+2)	26YD <sup>3</sup> (22+4)	27YD <sup>3</sup> (27+0)	29YD <sup>3</sup> (27+2)	31YD <sup>3</sup> (27+4)	33YD <sup>3</sup> (27+6)	31YD <sup>3</sup> (31+0)	33YD <sup>3</sup> (31+2)	35YD <sup>3</sup> (31+4)	37YD <sup>3</sup> (31+6)
A. Overall Length, Tailgate Closed (in.)	239	248	240	245	258	261	274	280	285	298	313	310	315	328	343
Overall Width (in.)	102	102	102	102	102	102	102	102	102	102	102	102	102	102	102
B. Overall Height Above Frame, Tailgate Closed (in.)	82	82	103	103	103	103	103	103	103	103	103	103	103	103	103
C. Overall Length, Tailgate Open (in.)	281	281	289	289	289	305	305	329	329	329	329	359	359	359	359
D. Overall Height Above Frame, Tailgate Open (in.)	165	165	197	197	197	197	197	197	197	197	197	197	197	197	197
E. Overall Length, Dumping Position (in.)	375	375	403	403	403	419	419	444	444	444	444	470	470	470	470
F. Overall Height Above Frame, Dumping Position (in.)	185	185	201	201	201	213	213	230	230	230	230	244	244	244	244
G. Overall Height Above Frame When Dumping (in.)	86	86	86	86	86	86	86	86	86	86	86	86	86	86	86
H. Overall Width, Arm Out (STD), Grabber Closed (in.)	204	204	204	204	204	204	204	204	204	204	204	204	204	204	204
I. Overall Width, Arm Out (LONG REACH), Grabber Closed (in.)	240	240	240	240	240	240	240	240	240	240	240	240	240	240	240
J. Overall Width, Arm In, Grabber Closed (in.)	134	134	134	134	134	134	134	134	134	134	134	134	134	134	134
K. Overall Width, Arm In, Grabber Open (in.)	102	102	102	102	102	102	102	102	102	102	102	102	102	102	102
L. Distance between bottom of Grabber & chassis frame rail (in.)	22/28	22/28	22/28	22/28	22/28	22/28	22/28	22/28	22/28	22/28	22/28	22/28	22/28	22/28	22/28

## Performance Specifications

Arm In (72" reach)	2.4 sec @ 700 rpm	Grabber Open	1.3 - 1.8 sec @ 700 rpm	Crusher panel Up	4 sec @ 700 rpm
Arm In (84" reach)	2.8 sec @ 700 rpm	Grabber Close	1.0 - 1.5 sec @ 700 rpm	Crusher panel Down	3 sec @ 700 rpm
Arm In (120" reach)	4.5 sec @ 700 rpm	Packer complete cycle without regeneration	12 sec @ 1200 rpm	Hydraulic chute to curb side	4 sec @ 700 rpm
Arm Out (72" reach)	3.2 sec @ 700 rpm	Packer complete cycle with regeneration	14 sec @ 700 rpm	Hydraulic chute to street side	4 sec @ 700 rpm
Arm Out (84" reach)	3.7 sec @ 700 rpm	Tailgate Open	21 sec @ 700 rpm		
Arm Out (120" reach)	6.0 sec @ 700 rpm	Tailgate Close (with Safety Flow limiter)	26 sec @ 700 rpm		
Arm Up	2.5 - 3.0 sec @ 700 rpm	Body Up (depending on body size)	30-40 sec @ 700 rpm		
Arm Down	2.5 - 3.0 sec @ 700 rpm	Body Down (depending on body size)	15-25 sec @ 700 rpm		

Note: Specifications subject to change without notice



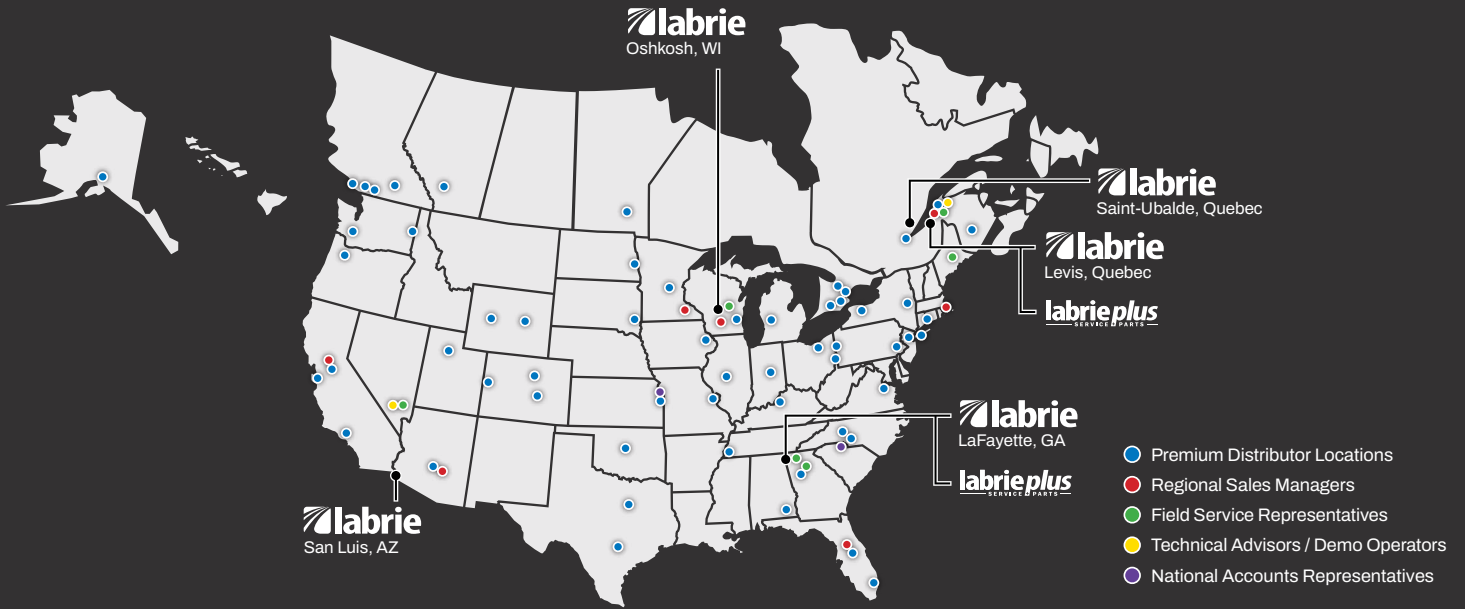

## Our North American network is dedicated to quality.

Labrie™ trucks are supported by over 30 top-tier distributors spanning across 50+ sites in the US and Canada, guaranteeing a commitment to driving excellence and providing expert support.



Opt for the Labrie™ Pronto Stock Program when a pre-built model makes sense. Benefit from expedited delivery, cost savings, and a wide selection of models designed to cater to even the most demanding collection needs.



With Sourcewell, save time and money by combining the buying power of more than 50,000 government, education, and nonprofit organizations.



# DRIVE EXCELLENCE™



175-B, route Marie-Victorin, Lévis, Quebec, Canada, G7A 2T3  
 Toll Free: 1-800-463-6638 | Telephone: 418-831-8250  
 sales@labriegrup.com | www.labriegrup.com



**United States of America**  
 1198 Shattuck Industrial Blvd, Lafayette, GA, 30728  
 Toll Free: 1-800-231-2771  
 usa.labrieplus.com | partscenter@labrieplus.com

**Canada**  
 175-A, route Marie-Victorin, Levis, Quebec, Canada, G7A 2T3  
 Toll Free: 1-877-452-2743  
 canada.labrieplus.com | labrieplusqc@labrieplus.com